



3M™ Fire Barrier Mortar

Product Description

3M Fire Barrier Mortar is a lightweight cementitious firestop product. It is available in poly/paper bags and ready for mixing with potable water. 3M Fire Barrier Mortar does not contain MMMF (man-made-mineral-fibers) or asbestos and does not require fibrous damming materials. 3M Fire Barrier Mortar contains binders free of portland cement and therefore has greater resistance to common concrete poisons than PC bound products. For use in mechanical and electrical penetration firestopping.

Product Features

- Variable Mix Ratio: permits self-leveling as well as no sag (no forming) application consistencies, resulting in labour savings
- Excellent Adhesion: will bond to concrete, metals, wood, plastic and cable jacketing
- Re-enterable without use of power tools: results in lower maintenance costs due to ease of making cable changes
- Bonds to Itself: proven prior and during fire testing, resulting in proven and tested repair procedures
- MMMF and Asbestos Free
- Polypropylene-Fiber Reinforced: reduces cracking during cure and firing
- Pumpability: allows faster installations, resulting in labour savings on larger projects and reduced installation time
- Excellent Heatsink: resulting in absorption of heat from penetrants, reducing the likelihood of ignition of combustible matter on the unexposed side of the assembly
- Compression Strengths: are between 1.3 to 5.45 MPa (186 and 790 PSI), depending on the water/cement ratio (1 part water to 2.5 parts powder to 1:4)
- Tested in accordance with AS1530.4, EN1366 and ASTM E814 (UL Listed).



Physical Properties

Typical Physical Properties	
Colour	Blue/Grey
Appearance	Solid powder with white particles and plastic fibres
Bulk Powder Density	600-910 kg/m ³ (37-57 lb/ft ³) range between loose and compacted powders
Wet Densities	1,100-1,900 kg/m ³ (68-119 lb/ft ³) depending on water/powder ratio and placement methods
Cured Densities	700-1,400 kg/m ³ (43-87 lb/ft ³) depending on water/powder ratio and placement methods
Compression Strengths	1.3-5.45 MPa (187-790 PSI) depending on water/powder ratio and placement methods

Availability

3M™ Fire Barrier Mortar is available from Authorized 3M Fire Protection Products Distributors.

3M Order Code	Packing	Unit/Case
98040026464	19.6 kg (44 lb)	1

Maintenance

Fire Barrier Mortar is expected to be stable indefinitely under normal conditions of use. Avoid presence of typical concrete poisons (i.e. sulfates, bleaches, etc.), which may deteriorate the product.



Installation Techniques:

- Clean opening and penetrating items from dirt and loose debris
- Wrap electrical cables and cable packs with a single layer of 3M Moldable Putty+ pads over the depth of the seal.
- Install damming if required (usually useful for floor openings greater than 20cm by 20cm). Use wood or 38mm+ polystyrene board . Forms will be removed after cure. When a consistency above 1:3 is used, forms can have larger holes in them without mortar leakage.
- Mask edges (not bonding surfaces) of opening and the ends of the penetrating items with 5cm wide masking tape, this will be removed after the install and will greatly help to improve the appearance of the finished job.
- Mix mortar as per the mixing instructions on this page.
- Wet down the opening with water, using a spray bottle or brush.
- Immediately place the mortar by filling the most difficult to reach areas first.
- Always work toward the sides (bonding surfaces) of the opening. Then squeeze mortar in against the sides.
- Smooth mortar off as quickly as possible after filling the opening flush with the wall or floor. It usually helps to use a variety of different shaped trowels for this work.
- Immediately after smoothing remove masking tape from the edges of the opening and penetrants by pulling away from mortar surfaces.
- After cure, remove any form work used during install.
- For large cable bundles, ‘inject’ 3M Fire Barrier CP 25WB+ Sealant into the bundles using the the nozzle of the CP 25WB+ cartridge.

Installed Mortar Thickness

- Electrical cables, metal pipes or blank (unpenetrated) seals: 120mm.

Mixing Instructions

- Add water to the mixing bucket first, and then add mortar, a little bit at a time, and mix using a large slow drill with a grout mixing paddle.
- The mixing ratio can be varied from 1:2.5 to 1:4 water:powder by weight. 1:3.5 is a typical consistency used when hand packing ‘balls’ of material into wall openings without the use of forms whereas 1:2.8 (a more watery mix) may be poured into a formed floor slab.
- Mix mortar until it is homogeneous and smooth, for a total of not less than 5 minutes. Watch for dry spots at the bottom edges of the bucket.
- For ‘remoistening’, avoid adding too much water. First try without adding any water. Do not remix more than once!

Tips:

Slumping corrections

When nearing the top of a wall opening if the mortar feels a little unstable, sprinkle a minute quantity of dry mortar powder on top, this will quickly stiffen up the mortar.

Weather Conditions

3M Fire Barrier Mortar sets fast and set time can be influenced by weather conditions. The hotter and dryer the weather, the faster the set time will be and the greater the likelihood of shrinkage. To minimise these adverse weather effects protect the seal with a sheet of plastic during the cure time.

Caution!

This mortar will conduct electricity when wet. DO NOT install in contact with live exposed conductors or old cloth style cable jacketing. Consult an electrician or electrical engineer in case of doubt.

This mortar is not intended to be load bearing. Do not walk on sections of mortar in floors. See ‘compressive strengths’ under the Physical Properties heading.



Performance Specifications for Installers

Australian Standard FRLs: Fire Barrier Mortar						
Building Element	Blank (Unpenetrated) Seal	PVC Insulated Cables, Cable trays and Cable bundles	Copper or Steel Pipes 54mm diameter or smaller 1.79mm Wall thickness or thicker	Steel Pipes 79mm diameter or smaller 2.29mm wall thickness or thicker	Copper or Steel Pipes Up to 152.4mm diameter	Brass Pipes Up to 101.6mm diameter
Floor: Concrete slab. <i>Minimum 120mm thickness</i>	-/180/180	-/120/-	-/120/-	-/120/-	-/90/-	-/90/-
Wall: Solid masonry, hollow masonry or concrete construction. <i>Minimum 116mm thickness</i>	-/180/180	-/120/-	-/120/-	-/120/-	-/90/-	-/90/-



In order to achieve the above FRLs you must ensure that the 3M™ Fire Barrier Mortar is installed as per the Installation Techniques and the building element you are installing into has an FRL performance equal to or better than that of the Fire Barrier Mortar. The Installation Techniques can be found on the final page of this document.

What does FRL mean?

FRL stands for 'Fire Resistance Level'. For example, an FRL of '-/180/180' indicates:

- **Structural Adequacy.** The first dash '-' indicates that Fire Barrier Mortar is non load bearing
- **Integrity.** The middle number '180' indicates for how many minutes the Fire Barrier Mortar system can resist the passage of flames and hot gasses
- **Insulation.** The last number '180' indicates how many minutes it takes the unexposed face to heat up by more than 140°C.



Performance Specifications for Engineers and Specifiers

3M™ Fire Barrier Mortar has been tested in accordance with AS1530.4-2005 and assessed in accordance with AS4072.1-2005 under BWA Report No: 23265. The following illustrations provide a summary of the test results for D1 and D2 cable configurations, metal pipes and blank (unpenetrated) openings with 3M™ Fire Barrier Mortar installed as per the Installation Techniques. Specifications for standard D1 and D2 cable configurations can be found in AS1530.4-2005 Appendix D.

D1 Cable Pack – Power Transmission Cables.

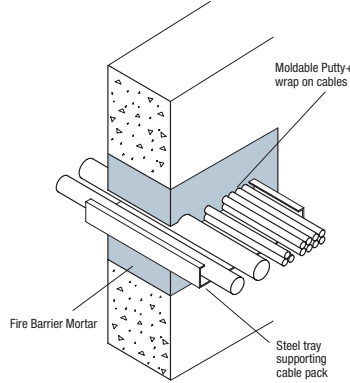

Solid Masonry, Hollow Masonry or Concrete Wall 120mm – FRL: -/180/60

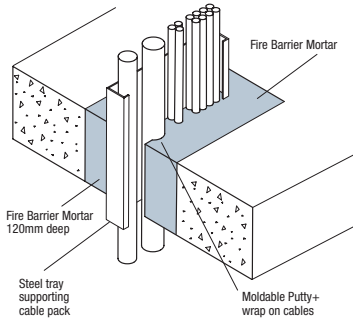

Concrete Floor 120mm – FRL: -/180/60

D2 Cable Pack – Telecom Cables.

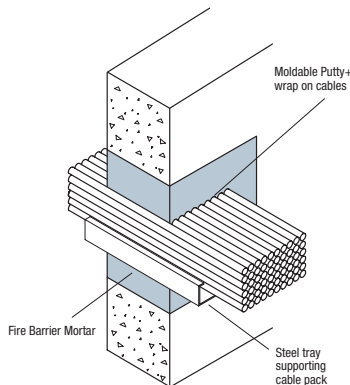

Solid Masonry, Hollow Masonry or Concrete Wall 120mm – FRL: -/120/-

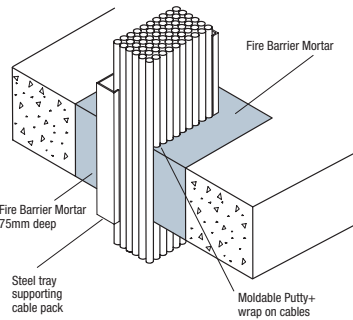

Concrete Floor 120mm – FRL: -/120/-

Blank Openings (unpenetrated)

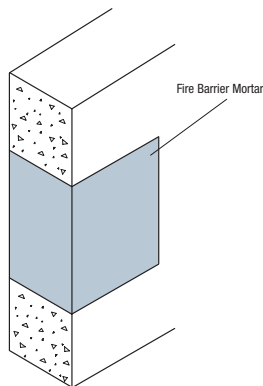

Solid Masonry, Hollow Masonry or Concrete Wall 120mm – FRL: -/180/180

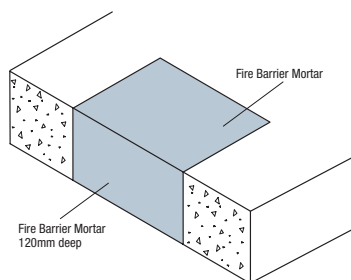

Concrete Floor 120mm – FRL: -/180/180

Metal Pipes

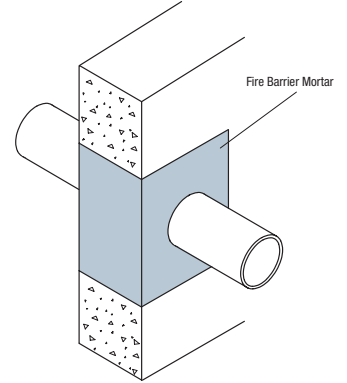

Solid Masonry, Hollow Masonry or Concrete Wall 120mm
Copper & Ferrous: 54mm dia, 1.79mm wall: FRL: -/120/-
Copper & Ferrous: 79mm dia, 2.29mm wall: FRL: -/120/-
Copper & Ferrous: 152.4mm dia, 1.63mm wall: FRL: -/90/-
Brass: 101.6mm dia, 1.22mm wall: FRL: -/90/-

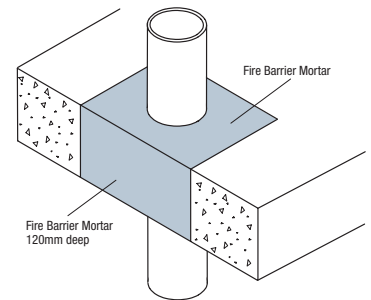

Concrete Floor 120mm
Copper & Ferrous: 54mm dia, 1.79mm wall: FRL: -/120/-
Copper & Ferrous: 79mm dia, 2.29mm wall: FRL: -/120/-
Copper & Ferrous: 152.4mm dia, 1.63mm wall: FRL: -/90/-
Brass: 101.6mm dia, 1.22mm wall: FRL: -/90/-

For further information Call: 136 136

TO THE EXTENT PERMITTED BY LAW 3M MAKES NO OTHER WARRANTIES INCLUDING, BUT NOT LIMITED TO, ANY IMPLIED WARRANTY OF MERCHANTABILITY OR FITNESS FOR A PARTICULAR PURPOSE. User is responsible for determining whether the 3M product is fit for a particular purpose and suitable for user's application. If this 3M product is defective within the warranty period stated above, your exclusive remedy and 3M's sole obligation under this warranty shall be, at 3M's option, to replace or repair the 3M product or refund the purchase price of the 3M product.

Limitation of Liability. Except where prohibited by law, 3M will not be liable for any loss or damage arising from this 3M product, whether direct, indirect, special, incidental or consequential, regardless of the legal theory asserted, including warranty, contract, negligence or strict liability.

Product Use: All statements, technical information and recommendations contained in this document are based on tests or experience that 3M believes are reliable. However, many factors beyond 3M's control can affect the use and performance of a 3M product in a particular application, including conditions under which the product is used and the time and environmental conditions in which the product is expected to perform. Since these factors are uniquely within the user's knowledge and control, it is essential that the user evaluate the 3M product to determine whether it is fit for a particular purpose other than those already stated by 3M, and suitable for the user's method of application.

Limitation Of Liability: Except where prohibited by law, 3M and seller will not be liable for any loss or damage arising from the 3M product, whether direct, indirect, special, incidental, or consequential regardless of the legal theory asserted, including warranty, contract, negligence or strict liability.

Energy Conservation Technologies

Unit 1 / 251 Ferntree Gully Road
Mount Waverley Vic 3149

Phone 1300 742 296

Email enquires@energycontech.com

Web www.energycontech.com